

# WEMSA

## CONSTITUTION RULES 2009

### TITLE

The Association shall be known as **THE WORLD & EUROPEAN MODEL STOCKCAR ASSOCIATION** and shall be the governing body for 1/8th scale model stockcars.

### OBJECTIVES

- (a) To promote the construction and racing of 1/8th scale radio controlled stockcars in co-operation with the national organisations.
- (b) To encourage national and international competition within a co-ordinated calendar on an equal level throughout the World.
- (c) To set rules and guidelines on competitive racing at international race meetings.
- (d) To promote and organise the World and European Championships (The European Championship will be held on the LAST or LAST BUT ONE Sunday in May or the 1<sup>st</sup> Sunday in June.. The World Championships on the FIRST or SECOND Sunday in September. The HOST club to inform WEMSA by the 1st DECEMBER of the previous year.
- (e) The location of all W.E.M.S.A. must be known at least 1 year in advance of the event and must also agree to adhere to the rules in force at the time of accepting the event.

### COMMITTEE ELECTIONS AND MEETING PROTOCOL

The committee shall consist of a Secretary/Treasurer for both Holland and the UK, plus six National Representatives from these two countries and one from America, excluding the Committee Officers (wherever possible for Britain 2 from each region). These positions will be held for a period of one year in the UK and two years in Holland, unless re-elected. Elections will take place at the National Organisations A.G.M.

No alcoholic beverage to be consumed during a WEMSA Committee meeting which will take place at 12.00 noon on the Saturday prior to the event and will last no longer than 1 hour.

Rule changes can only be carried if there is a 2/3rd majority vote (i.e. 12 voters - 6 for - 2 against - 4 abstentions)

### WEMSA'S AUTHORITY

The main objective of WEMSA is to encourage members to travel and to arrange facilities for those members.

An individual WEMSA Representative does not have any authority to make decisions on WEMSA's behalf, a minimum of two Representatives is acceptable. A WEMSA Representative has the authority to go anywhere on the circuit on the day of the WEMSA Championships, for example the lap-counting hut, scrutineering section etc. WEMSA will also advise of guidelines in racing construction and procedures.

### FEES

A Championship Contribution fee shall be reviewed and fixed half-yearly. Any administration expenses incurred by WEMSA Representatives during the year shall be given in writing, with receipts, to the Secretary/Treasurer before the annual meeting if reimbursements are required.

### GENERAL

- (a) WEMSA will set track and race facility standards for international race meetings.
- (b) The names of competitors will be notified to the organiser at least six weeks (or as soon as possible) in advance of the Championship by the WEMSA Representative.
- (c) The entry forms for the European and World Championships will be produced by the WEMSA Secretary and he will send the forms to the clubs in every country. The clubs will send the completed forms back to the WEMSA Secretary. An individual driver cannot submit a separate form to the secretary, with at least 2 (TWO) frequencies stated for each driver.
- (d) The official rules and procedures will be written in English, and translated into national language by WEMSA representatives if required.
- (e) Any banned driver of a club must NOT be allowed to enter a WEMSA meeting to be held at that club provided the national organisation (NSO and BRCA) are made fully aware of the situation.
- (f) Any club hosting a WEMSA meeting must abide by the WEMSA rules as they stand at that time. Should they not do so they will automatically ban themselves from hosting a WEMSA meeting for a period of one allocation.
- (g) Any driver found to be under the influence of either drugs or alcohol then he/she would receive a warning from WEMSA with possible repercussions as to them being allowed to attend a WEMSA meeting in the future.
- (h) Clubs hosting the World or European Championships must inform any visiting drivers, via the WEMSA committee, of any accommodation that is available or is to be provided at the time of the entry forms being distributed to the various clubs/countries.

# TRACK & RACE PROCEDURE

## 1. TRACK STANDARDS

Any club applying to host a WEMSA meeting must meet the following criteria:-

- (a) have an automatic lap counting system installed.
- (b) at the time of application have a permanent track that meets WEMSA requirements.

Any circuits constructed, provided they are of a raceable standard and acceptable to the national WEMSA Representative and WEMSA Committee, may be used if slightly outside the following specification/recommendations. Specifications of proposed sites for Championships must be submitted to the WEMSA Committee before acceptance of the Championship.

Recommended specifications for tracks are:

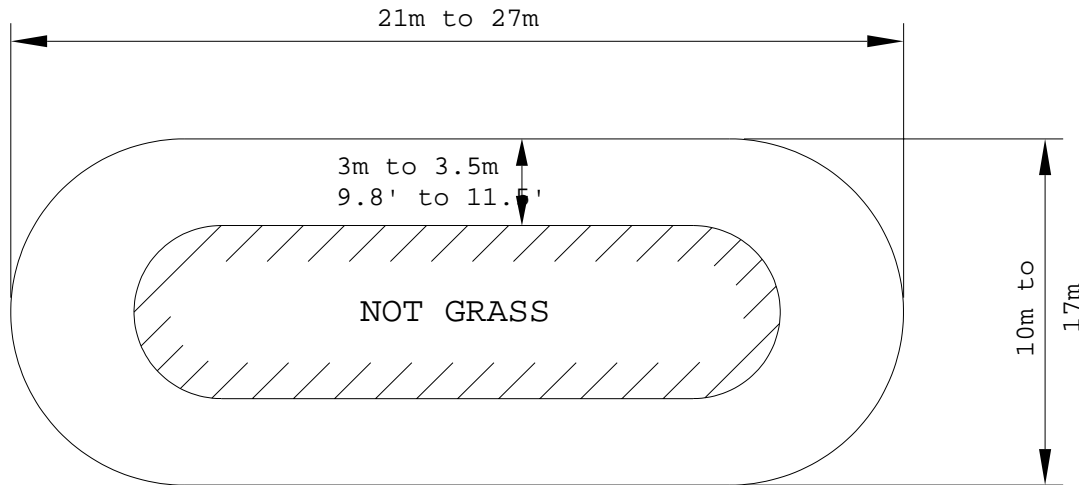

## **Facilities**

- Toilets to be provided
- Washing facilities would be advisable
- Tables for the pits are necessary with enough room for each driver and must be covered during European and World Championships
- The drivers rostrum will be covered.
- Public address system must be provided
- Public barriers around the circuit must be supplied
- First aid box must be provided
- Race numbers (1-6) should be placed under the lap scorer for each car. It is recommended that this is also done on the drivers rostrum so that the public can see who is operating the car.
- Lap scores must be displayed in order for the public/competitors to see clearly the result of each race.
- A contact telephone number shall be provided (this to be written on entry forms) to enable visiting drivers/helpers to be contacted in an emergency.
- Host club to provide a venue for WEMSA committee to hold a meeting. The meeting will take place at a suitable venue at 12.00 noon on the Saturday before the finals on the Sunday.

## 2a RACE PROCEDURES (ADMINISTRATIVE)

**ALL DRIVING WILL TAKE PLACE FROM THE ROSTRUM ONLY** (this includes all practice days)

(a) It is the responsibility of the National WEMSA Representatives in each country to decide who should compete if the race entries exceed the number of those allowed. It is recommended that Representatives choose the competing drivers either by earliest entry or by highest grading. Alternatively, the National Organisations may operate a system of qualification if they so wish.

For English and Scottish drivers grading period 3 of the previous year to be used for selecting the entrants for the European Finals and grading period 1 of the present year for the World Finals

(b) WEMSA World Championships will have a maximum of 96 drivers entering at one time. Each country is allowed the following number of drivers:

39 English, 39 Netherlands, 10 Scottish, 8 Others (including Italy/Germany/Belgium/American)

WEMSA European Open Championships will have a maximum of 96 drivers entering at one time. Each country is allowed the following number of drivers:

39 English, 39 Netherlands, 10 Scottish, 8 Others (including Italy/Germany/Belgium/American)

(c) If the club hosting the World or European finals wish to sort/grade the heats they may do so provided it is to the advantage of the running of the meeting.

(d) The National WEMSA Representatives will decide which club will host the meeting to be held in the country from the list of those clubs wishing to be considered. The WEMSA National Representatives must give reasonable notification to the

hosting club of a Championship to be held by them. Any club wishing to host an WEMSA meeting must have facilities to WEMSA standards up and running at the time they apply. The Championships will circulate the regions as far as possible.

(e) Every WEMSA World or European Championships will be run to WEMSA rules and recommendations.

(f) The circuit must be open a minimum of two days before a WEMSA Championship for practice between 0900-1800 hours. (or for a minimum of 8 hours).

(g) Host club to provide scrutineers, these to operate under the guidance of a WEMSA committee member.

The scrutineering equipment is to be made available from the Thursday onwards (the WEMSA Representative need only be in attendance on the day previous to the race day) and the results to be logged in a book and signed by the overseeing WEMSA representative, for reference over the weekend. This would give advance notice of any modifications that may be required prior to race day.

Official scrutineering on race day will be as follows:-

1. Any car may be checked at any time during the race meeting.
2. During heats - any two cars from heat.
3. Quarter finals - all six cars prior to heats
4. Semi finals - all six cars prior to heats.
5. Final - all six cars prior to final.

(h) The British WEMSA Committee have established a rota system for clubs eligible to host the World and European Finals (within Great Britain) as follows

2008	WORLD FINAL	EASTRAX
2009	EUROPEAN FINAL	NORA
2010	WORLD FINAL	SKEGNESS.
2011	EUROPEAN FINAL	LEICESTER
2012	WORLDS	NOTTS & DERBY
2013	EUROPEAN FINAL	EASTRAX

The above list to be adhered to but should a new club become eligible they would be slotted into 4th position in the above table and all other clubs below them to drop one place. Should a club decline to host its allotted meeting they will drop to the bottom of the list and the next one (in list order) be offered to host it.

If a club hosting either the WEMSA World or European Championships withdraws from holding the event within one year of the meeting date, then the previous club who hosted a WEMSA event in the same country is offered the opportunity to hold it.

If they should turn it down the previous club (again in the same country) is offered the event, and so on.

Any club refusing the event will not lose their place in order of obtaining the following WEMSA meeting.

(j) The maximum race entry fee for World/European WEMSA meetings will be as follows - 14 Euro's for each competitor ( 12 Euro's paid to the host club & 2 Euro's to WEMSA).

The maximum U.K. race fee will be £10 (with £1.00 going to WEMSA UK)

This to be paid by all drivers, in advance, to the relevant WEMSA secretaries who will be responsible for converting to the required currency and paying the host club.

The above fees will be reviewed in February and June of each year and any amendments made prior to entry forms being issued.

The advance booking-in fee will not be refundable in the event of the driver not attending, but will be refundable in the event of the driver not obtaining entry. This money will be paid to the host club, up to 96 drivers,.

(k) The drivers briefing information will be given in both English and Dutch. WEMSA Representatives will arrange this briefing. During the briefing it **MUST** be pointed out to all persons who may be marshalling that in the interest of safety marshals were to choose when it was safe to marshal a car and not to be intimidated by the driver.

(l) After the last heat and also between each Final, there will be a 'rest' period of approximately 10 minutes to 20 minutes maximum, to allow for minor car maintenance and frequency checks and changes, at the discretion of the WEMSA Committee.

(m) At least two WEMSA Representatives have the authority to speak with the race organisers at any Championships. If the race organiser does not accept WEMSA's decision given by the Representatives, then the race meeting is no longer a WEMSA Championship.

(n) Time is to be allocated within the programme for a group photo session. This to be after the drivers briefing and before the racing starts.

(p) After the heats will be Quarter Finals, Semi Finals and a Final, calculated from the best 2 heat scores added together. From every race in the finals the top three advance to the next stage. Quarter and semi final heats to be sorted by race organisers. WEMSA officials only to observe unless requested otherwise. During all Quarter Finals, Semi Finals and Final WEMSA representatives are to be located trackside, to observe drivers and marshals and a further representative is posted in the lap counting hut. For all finals a verbal warning will be given over the speaker system that the race is to start from a period of 5 (five) minutes before the start of the race (including the 2 minute warm up) and repeated at one minute interval.

Method of positioning top 24 drivers into 1/4 Finals

1/4 FINAL 1                      1/4 FINAL 2                      1/4 FINAL 3                      1/4 FINAL 4

QUALIFYING POSITION	1	2	3	4
QUALIFYING POSITION	8	7	6	5
QUALIFYING POSITION	9	10	11	12
QUALIFYING POSITION	16	15	14	13
QUALIFYING POSITION	17	18	19	20
QUALIFYING POSITION	24	23	22	21

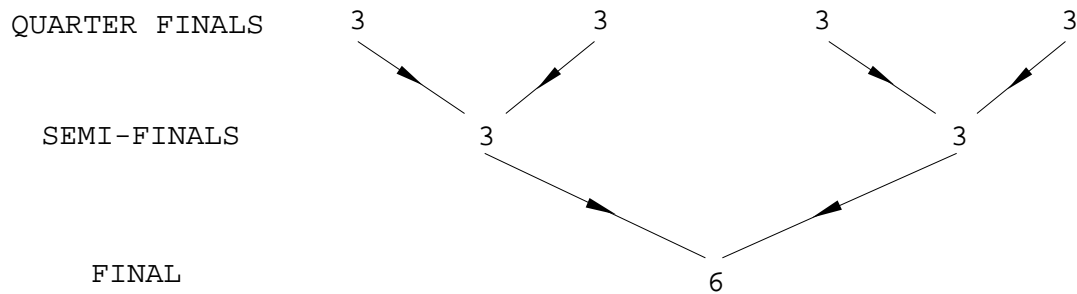

(r) The race organisers will be responsible for buying trophies for each Championship. The minimum number of trophies to be bought are; 24 reasonable sized trophies for the 1st-24th places if there are more than 60 drivers. When there are less than 60 drivers, there has to be 12 trophies for the 1st-12th place. Each competitor must also receive a small commemorative trophy. Trophies should have the drivers finishing position on the trophy.

(s) Radio checks to be carried out (by a WEMSA official) prior to each of the 4 quarter finals, 2 semi finals and final These to be carried out in the following order:-

1. Quarter finals - heat 4 first.  
heat 3 second.  
heat 2 third.  
heat 1 fourth.
2. Semi finals - heat 2 first  
heat 1 second.

Radio checks will be carried out in the following way.

- (s1) All drivers to be on the drivers rostrum.
- (s2) Cars to be placed on the track in front of the rostrum.
- (s3) All transmitters to be turned on.
- (s4) All cars to be turned on.
- (s5) All drivers in turn check both the throttle and steering servo's.
- (s6) All cars turned off.
- (s7) All transmitters turned off.

(u) Transmitters will only be allowed to be returned to their owners before the end of the race meeting provided a WEMSA representative is accompanying them when they are collected from the transmitter compound and the driver is leaving the track.

(v) Should a mechanic release a car from the start line prior to the start light coming on or the horn sounding then a 1 (one) lap penalty will be imposed on that particular car. This to be decided by race control or a WEMSA official and to be announced over the loud speaker system while that particular race is in progress.

(w) All drivers to be issued with a peg with their name clearly written on. These to be placed on the frequency board by the driver when taking his/her allotted frequency peg. This procedure is also to be adopted during practice days.

(x) It is recommended that the top 24 qualifying drivers be informed by race control as soon as possible, that is prior to the quarter final heats being sorted.

(y) Application forms that are returned to the UK WEMSA Secretary by UK clubs for driver entries to WEMSA meetings must give all information as requested. Failure to do so will result in the driver **NOT** gaining entry to a World or European Final. It is the responsibility of the club to give this information **NOT** the WEMSA Secretary.

(z) All racing at W.E.M.S.A. meetings will finish at 6.00. p.m.

## **2b RACE PROCEDURES**

### **1. Driver and car**

a) All drivers wishing to attend and race at a WEMSA meeting must be a member of their National Organisation and a member of a recognised club. No driver shall be eligible to compete in any WEMSA meeting unless his car conforms to the present Association specifications. Cars may be scrutineered at any time during a race meeting.

b) Drivers are responsible for the behaviour of any marshals, helpers or family that they bring with them to a WEMSA meeting. If an incident is reported to a WEMSA official that has brought the sport into disrepute, including acting in

an unsports man/un gentlemanly manner be it on or off the track, the WEMSA officials will decide what action should be taken. This can result in disqualification or a ban from WEMSA race meetings.

**2. Race Direction**

All races will be run in an anti-clockwise direction.

**3. Starting Procedure.**

Drivers will take up their starting positions altogether on one line at the beginning of a straight, regardless of roof grade. This position will be indicated on the running surface or safety fence of the track.

**4. Clutch Starts**

All heats and finals will be hand held starts.

**5. Method of Starting**

All drivers will have an audible warning of 2 minutes, 30 seconds (hold the cars) and 15 seconds. Drivers names will be called out at the beginning of each race.

**6. Race Duration**

All heats will be 4 minutes duration. Quarter finals, semi- finals and final will be of 5 minutes duration.

**7. Race Finish**

The finish signal will also be by horn or hooter.

**8. Stoppages**

(a) Cars stopped during a race can be returned to the circuit provided no other cars are obstructed in doing so, at the discretion of the race organiser.

(b) No major repairs to cars may be carried out on the racing surface or infield the track.

(c) If the cars silencer or bodyshell becomes detached from the car, it must be removed from the track and repaired. If the car continues to race, no laps will be counted.

**9 Race Frequencies**

All races to have a maximum of 6 cars racing at one time. Spot frequencies to be used, but when necessary other frequencies may be used. Drivers must have at least two frequencies available. Where frequencies conflict in finals, the fastest qualifier shall choose providing it is possible for the other driver(s) to change to other available frequencies.

**10 Radio Interference**

Heats will not be stopped for radio interference, checks will be carried out after the race and if a fault is found to be caused by another driver, an average will be given, and crystals changed. For Finals, frequencies will be checked in race order before the start of the racing.

If the cause is due to error of the race organisers the heat will be re run and the highest lap score of the two races given (note- all heat drivers must at least start the re run)

**11 Race Grids**

The race organiser is responsible for race grids. The method of deciding positions for the finals will be taken from the highest two scores out of the three heats. In the event of two or more drivers getting the same number of laps (example A) the highest discarded lap will decide the tie or if this is not possible (example B) then the highest lap scored will be used. If still undecided, lap timings on the discarded heat would be used, or if no split timing is available, an extra deciding race of 20 laps between the drivers concerned would take place.

EXAMPLE A	DRIVER C 36 34 18 DRIVER D 36 34 17	DRIVER C QUALIFIES
EXAMPLE B	DRIVER C 36 35 18 DRIVER D 37 34 18	DRIVER D QUALIFIES

**12. Roof Colours**

World Champion - Gold Roof  
European Champion - Silver Roof

**13 Smoking**

Smoking will not be allowed on the rostrum at any time.

**14 Marshalling and Helpers**

Preliminary heats  
All drivers from previous heat to marshall.  
Marshalling for Finals  
Heat 4 of quarters to marshall heat 1  
Heat 1 of quarters to marshall heat 2  
Heat 2 of quarters to marshall heat 3  
Heat 3 of quarters to marshall heat 4  
Quarters 1 and 2 loosing finalists to marshall semi final 1  
Quarters 3 and 4 loosing finalists to marshall semi final 2

Loosing semi finalists to marshal the final  
The names of marshals will be called out at 2 minutes before the start of the race.  
If they are unable to marshal they must inform a WEMSA official and nominate someone in his/her place.  
Should the above fail to be observed 10% of the total of their best 2 qualifying scores will be deducted (this to be rounded down).

EXAMPLE-----      74 LAPS TOTAL SCORED  
                                 7.4 LAPS DEDUCTED  
                                 GIVES 66.6 LAPS  
                                 ROUNDED DOWN TO GIVE 66 LAPS TOTAL

WEMSA officials will oversee the marshalling and should a driver NOT marshal, after being reminded, the above rule will apply. This to be reported to race control immediately.  
Markers for marshalling points will be placed around the track. Helpers will not be allowed around the drivers rostrum during racing but will be allowed around other parts of the circuit to assist their driver, but must stand back to give official marshals ample opportunity to carry out the allotted task.

**15. Damage/Radio Problems**

Any car with damage/radio problems that maybe causing problems to other drivers during a race is to be removed from the track. This is to be the decision of the race organiser.

**16. Signalling.**

The use of headphones or any other signalling device (that is being used for the purpose of co driving) are banned from use by drivers/mechanics.

This includes the use of hand signals from the track side to the driver on the rostrum.

**17. Pit Area**

Only members of the NSO and BRCA are allowed in the pit area (other than WEMSA officials).

**18. Practice**

After the free practice on Sunday morning there will be an official timed practice in heat order (1 to 16). No practising will be allowed after the start of the meeting. Practice supervision will be carried out by WEMSA representatives wherever possible.

At no time during any practice should there be more than 6 cars on the track and drivers must only drive from the rostrum (NOT TRACKSIDE). It is the responsibility of the host club to monitor the situation but WEMSA will assist should this be required.

Refuelling during each practise run will **NOT** be allowed. Should anyone be found doing so, then practice is to be stopped until the situation is rectified and the offending driver penalised accordingly.

**19. Throwing of cars**

Cars are **NOT** to be **THROWN** from one person to another. Any car that is seen to be thrown both the offending person/persons and the associated driver will be dealt with seriously by the WEMSA committee resulting in disciplinary action being taken.

**20. Back up lap counting**

A second/backup manual lap counting system is to be in operation at all times during race day. This to be run completely separate of the automatic system (for example they can take the form of flip cards/clickers/pencil and paper)

**W.E.M.S.A. European & World Junior Championships.**

1. This will be open to any driver who is under 16 years of age on 1<sup>st</sup> January in the year of the event..
2. The top 6 junior drivers from the qualification round for the main championship will qualify for the junior final.
3. If any of the junior drivers qualifies for the main final then the junior final will follow the main final, if this is not the case then the junior final will take place prior to the main final.
4. The host club will supply a trophy for each driver of the junior final.

**3. PROTOCOL FOR CEREMONIES**

The following are recommendations for the protocol of Championships and presentation ceremonies;

- (a) All competing countries national flags to be on display throughout the Championship
- (b) There shall be a formal introduction of the 6 finalists to the public. The suggested time for this is during the frequency check prior to final.
- (c) A WEMSA Official must take part in the prize-giving ceremony.
- (d) A podium must be provided for the first three placed drivers to stand on. When all three drivers are in position, the winner's national anthem will be played.
- (e) It is recommended (but not required) that a commentary be given of the races for the viewing public. Any results given by the commentator are unofficial and should not be questioned by the drivers.

**4. NOTES.**

Where ever the host club should organise some form of entertainment such as a Bar – B – Q. This is not compulsory but Help in cementing relation between all drivers.

**CONSTRUCTION RULES**

## **CONSTRUCTION RULES**

1. Models are to be 1/8th scale and a reasonable reproduction of a full-sized stockcar (note: 'reasonable reproduction' means bodyshell must not have wheel covers or extend over side bumpers). The drivers' full name and racing number must be on the outside of the cars' bodyshell
  2. Overall length to be between 41cm and 45cm
  3. Overall width to be a maximum of 21cm-24cm
  4. Maximum weight of car to be 4.0Kg. Minimum weight of car to be 3.5Kg. Weight to be taken as ready to race with a full tank of fuel. In wet weather condition 4.2Kg will be permitted but must be below the 4.25 Kg prior to the race.
  5. Front and rear bumpers must be fitted and with a touching surface of between 10mm to 20mm. The distance between the bumper underside and the ground must be 30mm minimum and 45 mm maximum. All bumpers, chassis and rails must be plugged, filled and have no sharp edges (including antenna).
  6. Overbumpers must be fitted to front and rear bumpers. The height from the top of the bumpers must be 5cm maximum for both front and rear and 1.5cm minimum.
  7. Side bumpers must be on the same level as the front and rear bumpers and have a touching surface of 6mm minimum to 20mm maximum.
  8. Tyres may have a maximum width of 35mm.
  9. The maximum engine size is 3.5 cc or 0.214Cu Ins of single cylinder construction. Any driver may challenge the capacity of any competitor's engine. The challenger must pay a deposit of £70 (100 Euro) to WEMSA. If the challenge fails then the deposit is retained by WEMSA, if the challenge is positive then the deposit is returned to the challenger, and the guilty driver will be disqualified from all WEMSA events for LIFE.
  10. The engines must be silenced to the satisfaction of the WEMSA Representatives.  
The limits will be
    - a) In Holland - 80dB at 7 metres or 100dB at 1 metre at 1 metre high
    - b) In United Kingdom - 80dB at 10 metres or 100dB at 1 metre at 1 metre high
- All parts of the exhaust system must be inside the bodyshell or under the car.
11. The chamber (can) of the exhaust system must be contained between 2 vertical lines taken on the outer side of the chassis tubes at the point where the swinging arms touch the chassis.

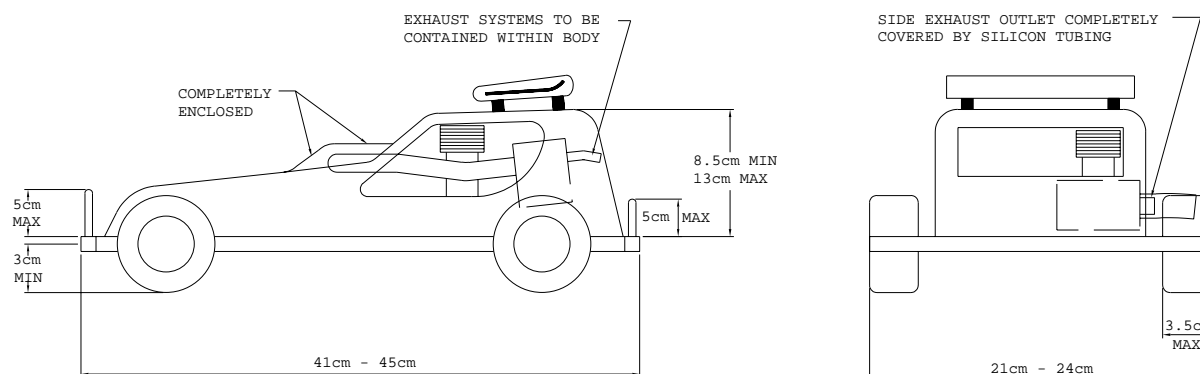

DIAGRAM OF WHERE EXHAUST-PIPES CAN BE POSITIONED

11. The height of the body from the top of the body to the top of the chassis is limited to 8.5cm minimum and 13cm maximum, (this is to be taken from the top of the body and not the spoiler if fitted (see drawing above)
12. External roll bars are not permitted when racing.
13. Spoilers/Aerofoils may be fitted but must not extend beyond the outer edges of the chassis or bumpers. They must be made of plastic not metal. There is no height limit to the spoiler, spoilers must be painted in the same colour as the drivers roof grade. The maximum size of the aerofoil Uk 6" by 6" In Holland 17cm \* 17cm. The roof or aerofoil of the car must reflect the drivers grade.
14. No electric stock cars may compete at WEMSA Championships.
15. Roof number fins are optional. If used, they will be plastic
16. No chain driven cars will be allowed to compete.
17. The chassis must be made of steel.
18. Exhaust pipes must not point upwards and be contained completely within the bodyshell. (see diagram)
19. No brakes will be allowed during WEMSA Championships.
20. No differentials will be allowed in any part of the car.
21. No tyre additives are allowed.
22. Engines, gearing and transmission must be inside the chassis rails, any unorthodox construction will be subject to WEMSA approval.
23. Only single gear/direct drive cars using a single belt will be allowed to race.
24. Bearings may be used on the running gear of the car.
25. Any part of the car may be substituted during a meeting with the exception of the chassis.
26. Wheelbase can be any length providing the wheels are kept within the confines of the chassis.  
Notes for rules 2,3 and 5 – The car should be just lifted gently and allowed to find its own resting position, the bumper height measurement will then be taken. No force will be used to get the car into the box.
27. Any under tray must not protrude beyond the outer edge of the chassis rails.

**IN THE CASE OF THESE RULES BEING**

**INSUFFICIENT, THE WEMSA REPRESENTATIVES  
DECISION WILL BE FINAL**

Amended September 2008.